

Bonfiglioli Solutions - Power

11 Sep 2024

Hyderabad

Sivakumar Natarajan

Application Engineering
I & AS Business Unit



We engineer dreams

Market Leader in Power Transmission Portfolio with Global Footprint

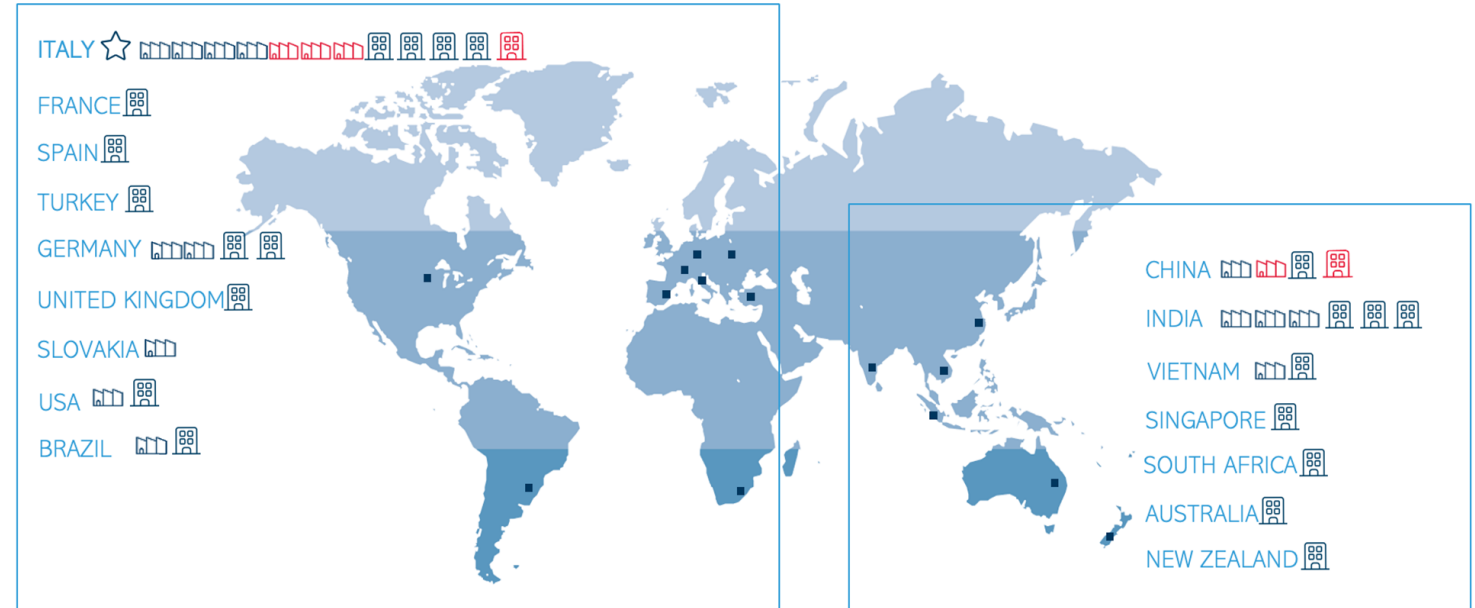

☆ HEADQUARTERS
🏭 PRODUCTION SITES
🏢 COMMERCIAL SITES
🏠 SELCOM GROUP

15 PRODUCTION SITES
24 COMMERCIAL SITES
80 COUNTRIES
~4.000 PEOPLE

25 Years of Commitment in India



Engineered Solutions: Driving India Growth Story



4 State of Art Factory



All India Service



India Design Centre



> 1000 People

Keep the World in Motion



18 Sales Offices

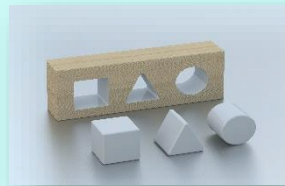

Centre of Excellence-Application

Make in India

- India for India
- India for Global



40 +Sales Partners



Dedicated After Sales Team

Positioning of Light & Medium Gearboxes among Bonfiglioli products

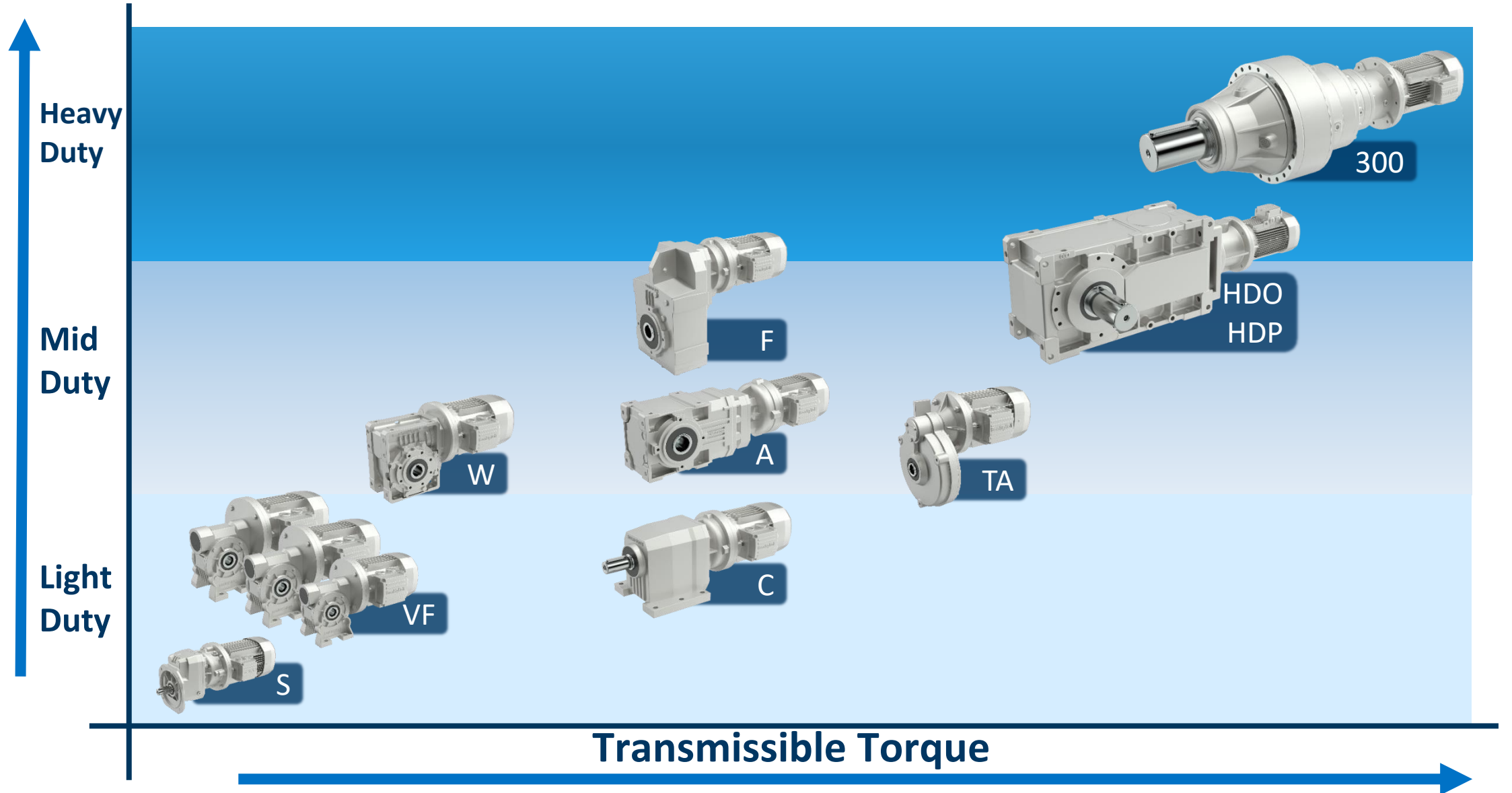

Bonfiglioli Product Range

Gear Motors and Gear Box

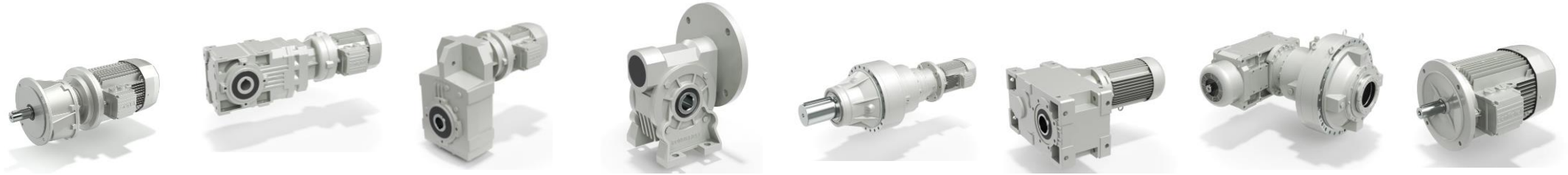

	AS/C	A	F	VF/W	300	HD	Combined	Motors
Type	In-Line Helical	Bevel Helical	Parallel Shaft Helical	Worm	Planetary	Heavy Duty Bevel Helical	Heavy Duty – Planetary / Helical	IE2, IE3, BSR
Torque Range (Nm)	45....12000	100....14000	140..14000	13....7100	1250.... 12,90,000	5190.... 209,900	100,000.... 12,90,000	0.37 22KW
Mech Rating kW @ 1400RPM	0.08..213	0.22..151	0.17..123	0.03..55	0.07 ..200	8.. 2796	10 .. 867	
Ratios	2.6..1481	5.4 ..1715	6.4..2188	7...10000	3.48..5000	7..534	18.1..5234	

MARKETS WE SERVE

Power Plants



- Wagon Tiplers
- Side Arm Chargers
- Stacker / Reclaimer
- Apron Feeders
- Pan Conveyors
- Crushers / Mills
- Bulk Reception Units
- Paddle Feeders
- Coal and Ash Handling Systems
- Pan Conveyors
- Electrostatic Precipitators

OEM & END USER REFERENCE



Stacker and Reclaimer

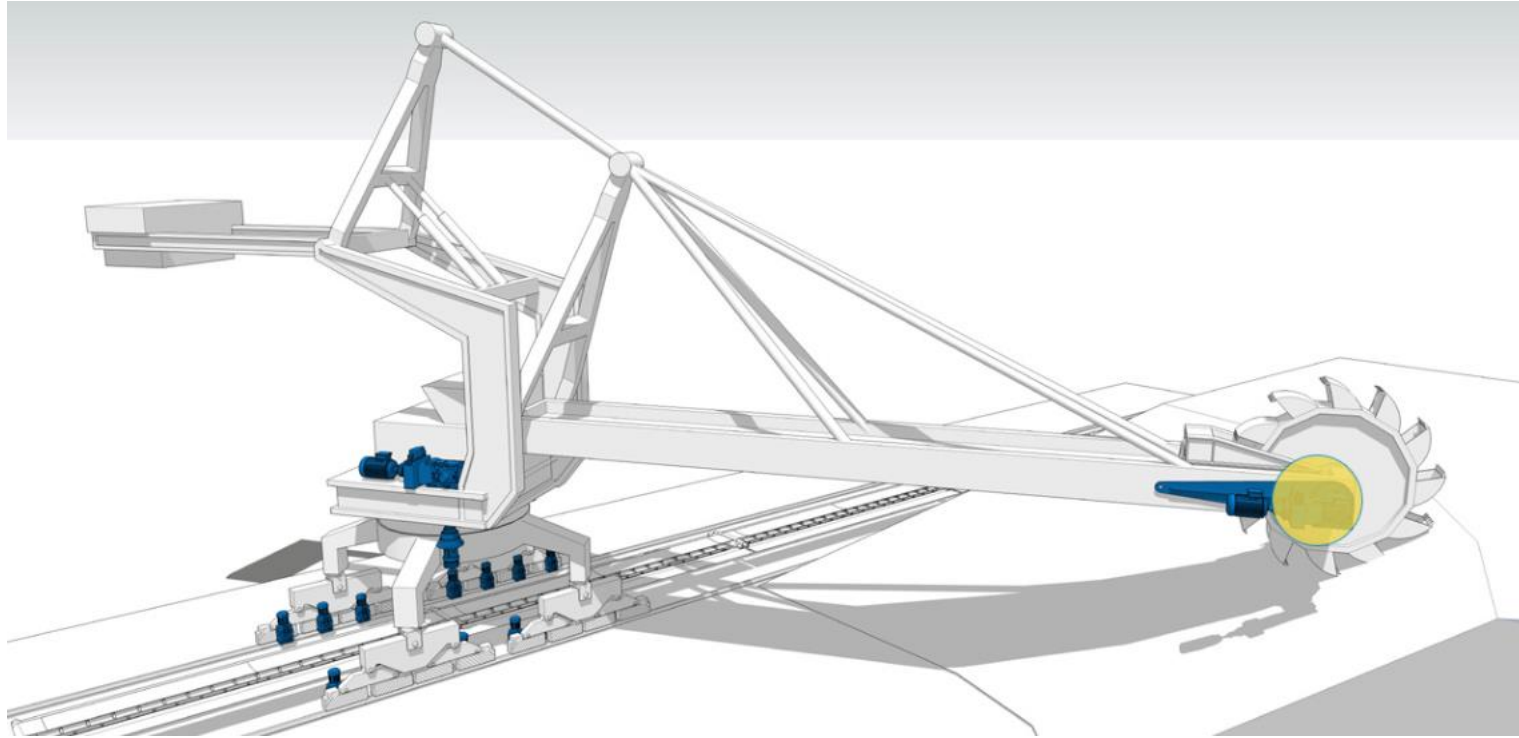

Major Customers



Feeders



Apron Feeder – Mining

Product : 3 17- 02 No's
Supply Year : 2021
Project: NALCO

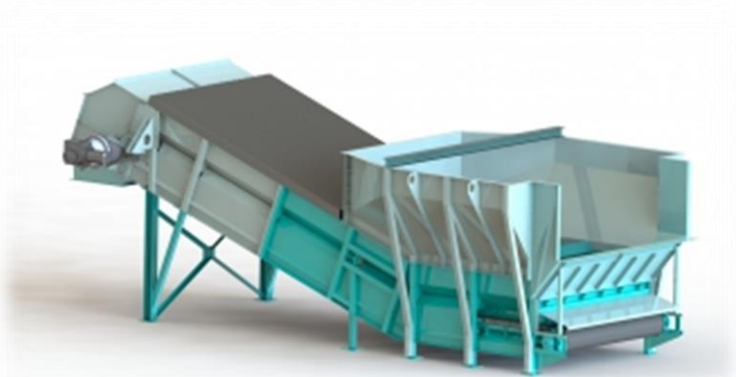

Bulk Reception Unit Coal / Iron Ore

Project: NTPC - FGD
Product : X_3 17 + BE
180 M4 415-50 CLF
B5
Supply Year : 2020

Truck Unloading System



Project: NTPC Unchahar
Product : 3 14 + IEC Backstop - 03 No's
Supply Year : 2021

Product : 3 14 + TA + Siemens IE3 15
KW Motor - 03 Nos
Supply Year : 2020
End User: Chettinad Cement – Dachepalli

Coal Handling

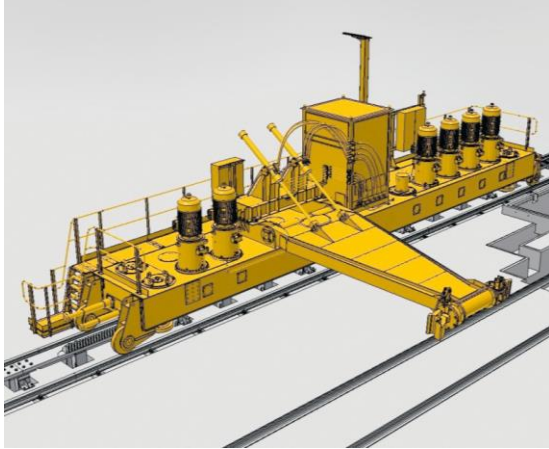

Side arm charger

Product: 3 13 L2
Quantity: 26 Nos
Sector: Steel and Power

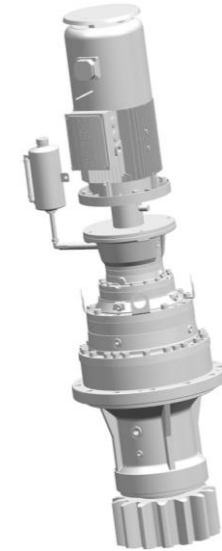

Wagon Tippler

Product: Helical / Planetary
Quantity: 2 Nos
Supply Year: 2013
End User: Steel and Power

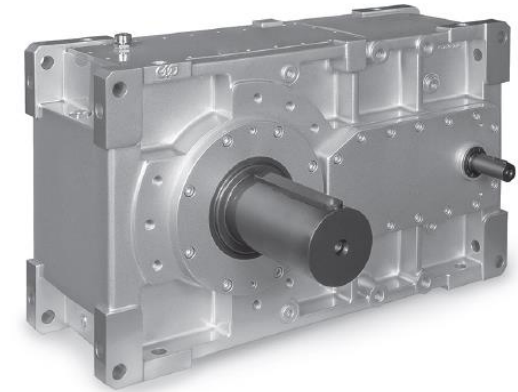

Coal / Ash Handling Plants

Pan Conveyor / Belt conveyors



Application – Pan Conveyor (Ash)
Project - NTPC
Model - 3 19 R 4 401 FP P280 B0 G0A
Power - 55 kW / 2.5 rpm
Rated Torque – 384,100 Nm
Accessories – Torque Arm, Shrink Disc



Application – Belt Conveyor
Model – HDO 100 3 25
Power - 75 kW / 59 rpm
Rated Torque – 24,300 Nm
Accessories – Brake, Fluid coupling

Paddle Feeder

3 00 L 4 447 PC P71 E BE 71B 4 230/400



Application – Paddle Feeder
Model – 3 / H 17 O L2 89.6 FZ
Type – Planetary & Bevel Helical
Power - 132 kW / 11 rpm
Rated Torque – 157,000 Nm
Accessories – Axial fan, Motorised Pump

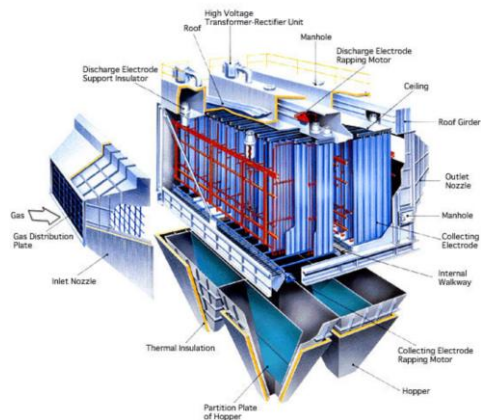

Application – ESP
Model – 300 L 4
Power - 0.37 kW / 3.2 rpm
Rated Torque – 1,300 Nm
Speciality – 4 and 5 stage Planetary

Case Study - 3; Conventional Bevel Helical Vs Planetary

Applications – BRU, Apron Feeder and Pan Conveyor

	Equivalent model of Bonfiglioli	Planetary solution (Bonfiglioli)
Model Configuration	HDO 140+ AS 80 + BE 160M 4	3 15 L 4 + TA + BE 160M 4
Ratio	1123	1104
Mn2 (Nm)	87060	94800
Pn1 (kw)	11	11
Weight in kgs (Approx)	2250	800
Oil quantity	100	22
Oil change frequency	12500 h	12500 h
List Price per unit (Without motor)	2892000	1650000
Overall life hours (Gears)	> 50000	>50000
Overall life hours (Bearings)	> 50000	>50000
Efficiency	87%	88%
No of stages	6	4

- Planetary gear units weigh lesser and use lesser lubrication oil
- Low initial cost and total cost of ownership

Other Important Projects



Apron Feeder



- Model: 3 17 R4, 3/H 17
- Type – Helical Planetary



Railway Wheel Machining



- Model: A 35 & F 60
- Type – Bevel Helical



Bulk Reception Unit



- Model: 3 11 – 3 17 R4
- Type – Bevel Planetary



Reactors / Agitators



- Model: HDO 120 / 125
- Type - Vertical Helical



Travel Drive



- Model: A 70, 80 and 90
- Type - Helical - Bevel



Desolventizer Toaster



- Model: HDO 180
- Type- Bevel - Helical



Vertical Crystalliser



- Model: 3 18 L5
- Type - Planetary



Spherical Drier



- Model: HDP 150
- Type – Vertical Helical



PSLV 9 - Launching pad



- Model: RAN 18
- Type – Bevel (RAN series)

THANK YOU

We engineer dreams

 **Bonfiglioli**